





Turbocharger Failure Diagnosis Guidelines

Impact damage	Foreign object damage to impeller 	Foreign object damage to turbine wheel 	<p>Never continue to operate an engine with a suspect or noisy turbocharger as this could result in total engine failure.</p> <p>Impact damage caused by foreign material entering the turbine housing or compressor housing is clearly visible on the turbine wheel or impeller.</p> <p>Never continue to operate a turbocharger with damaged blades as the rotor balance will be affected and this could impact its service life.</p>
	Insufficient oil supply	Effects of using silicone sealants 	Insufficient lubrication oil 
Dirt in oil	Dirt scored shaft 	Dirt scored bearing 	<p>Dirty oil damages the turbocharger by causing heavy scoring of critical bearing surfaces. To avoid damage, oil and filters should be of a quality recommended by the engine manufacturer. These should be changed when a new turbocharger is fitted and at regular intervals according to the vehicle/engine manufacturer's specification.</p> <p>Dirty oil damage could result from:</p> <ul style="list-style-type: none"> Blocked, damaged or poor quality oil filter Dirt introduced during servicing Engine wear or manufacturing debris Malfunctioning oil filter by-pass valve Degraded lubrication oil.
	Carbon build-up	Bearing damage due to hot shutdown 	Carbon build-up on shaft 

Before changing your turbocharger, please make sure that you have correctly identified the cause of the fault.

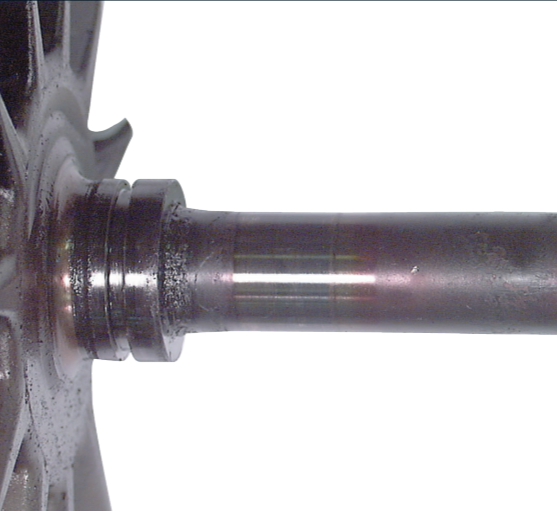
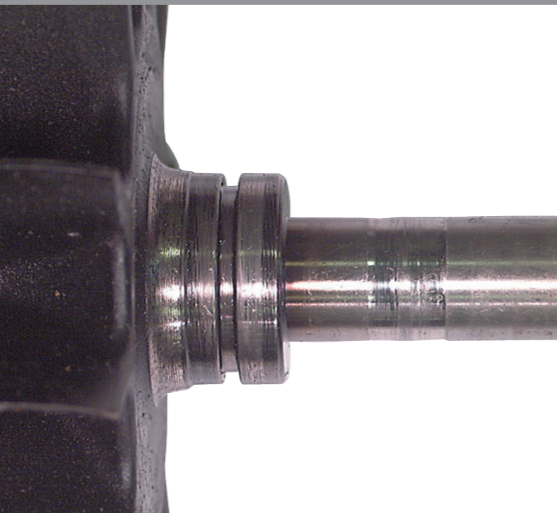
Excess smoke	Engine lacks power	Noisy/Whistling	Seized/Sluggish	Worn/Excessive clearance
<p>Caused by:</p> <ul style="list-style-type: none"> Dirty air cleaner Air intake system restriction Cracked mounting flange/gasket missing Fuel pump/injectors/valve timing incorrectly set Wastegate mechanism set incorrectly Turbocharger damaged. 	<p>Caused by:</p> <ul style="list-style-type: none"> Dirty air cleaner Air intake system restriction Cracked mounting flange/gasket missing Exhaust for foreign object restriction Fuel pump/injectors/valve timing incorrectly set Burnt valves and/or pistons Turbocharger damaged. 	<p>Often the noise comes from air/gas leakage due to pre-turbine exhaust gas or air/boost leaks.</p> <p>Check all joints. If noise continues, check turbocharger clearances and wheels for housing contact.</p>	<p>If the turbocharger rotor assembly has seized or is tight to rotate, this is often due to lubricating oil degredation, which can cause a high build up of carbon in the bearing housing interior, restricting rotation. Insufficient or an intermittent drop in oil pressure can cause the rotor to seize, as can introducing dirt into the lubricating oil.</p>	<p>A turbocharger has specific axial and radial rotor clearances. These are sometimes mis-diagnosed as 'worn bearings' (See engine manual or nearest authorised Holset distributor). If the clearances are out of specification the cause could be attributed to a lubricating oil problem, i.e. insufficient oil, dirt ingress, oil contamination with coolant.</p>

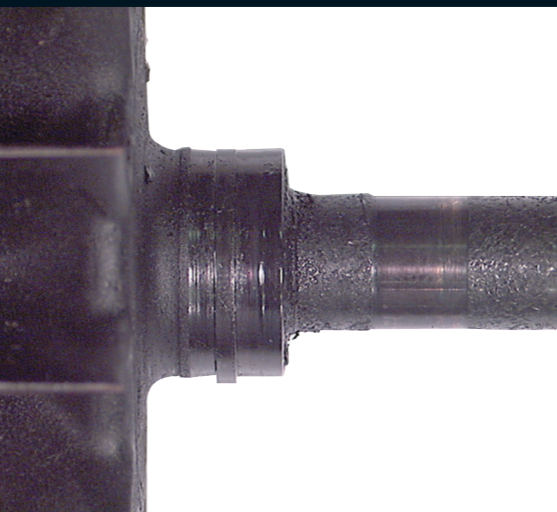
Remember, if the root cause of the problem is not identified and corrected, your problem will remain!

For more information visit:

www.holsetaftermarket.com

HOLSET[®]
TURBOCHARGERS

Turbocharger Components Identified

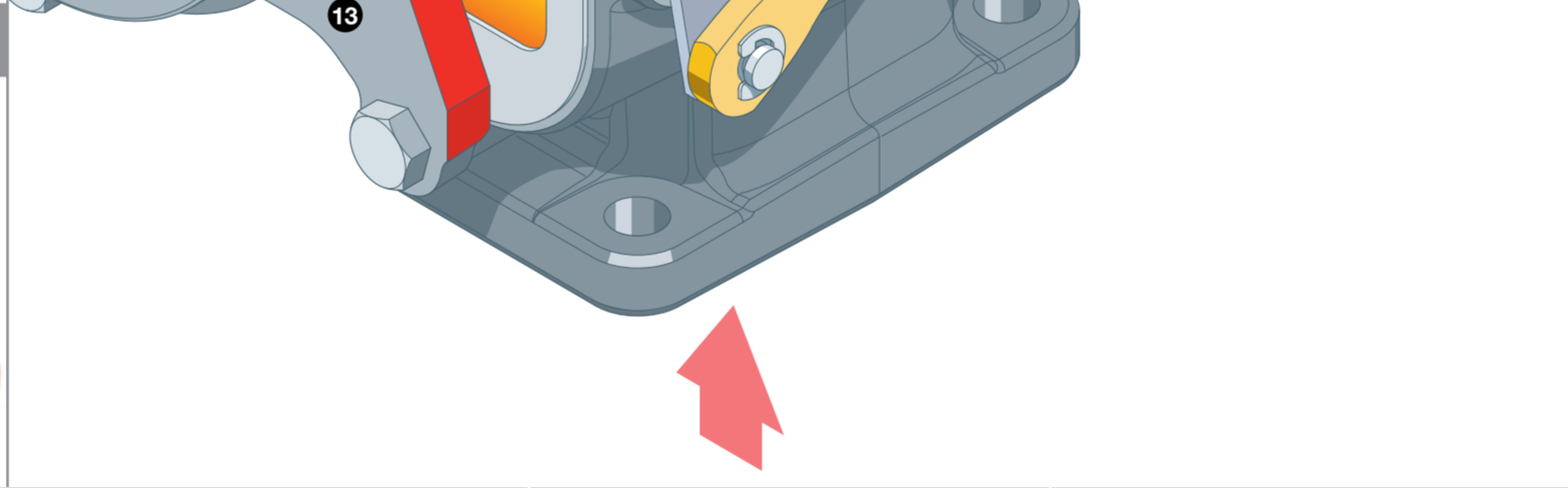
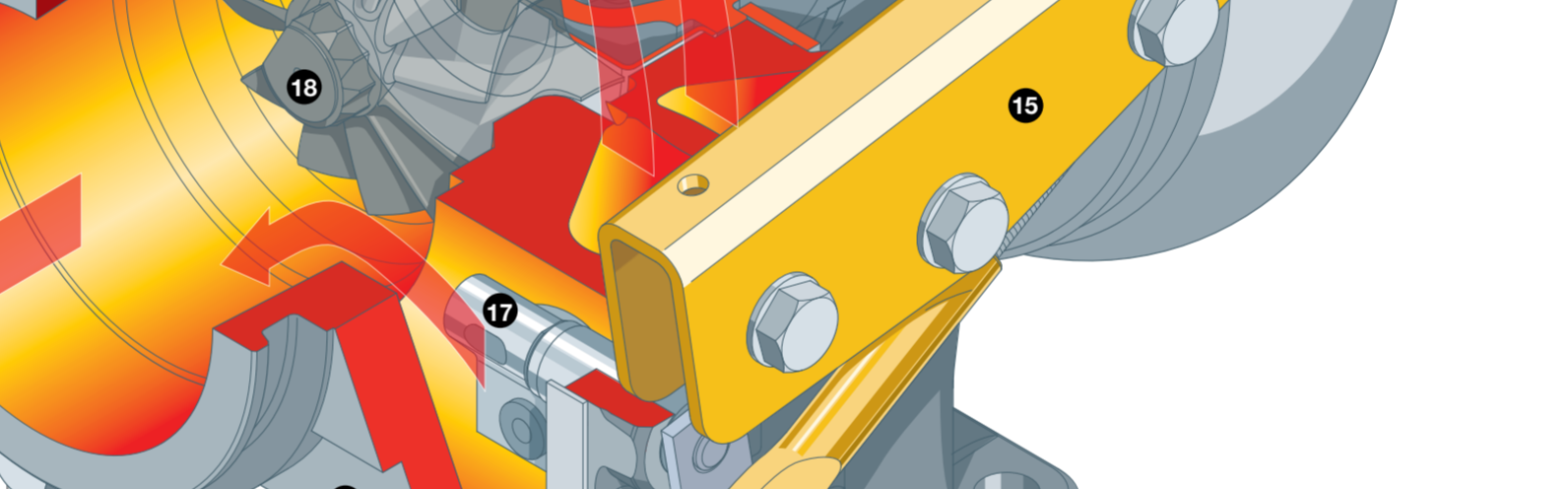
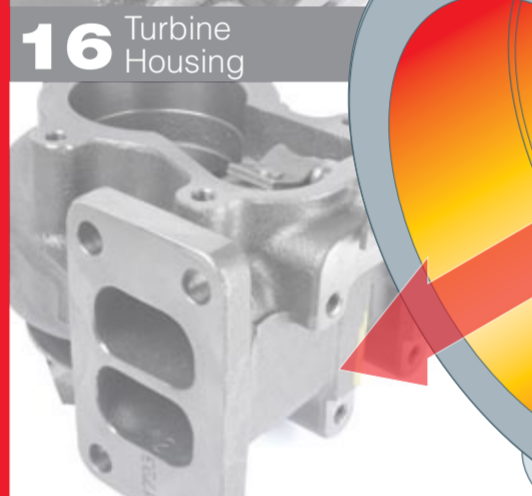
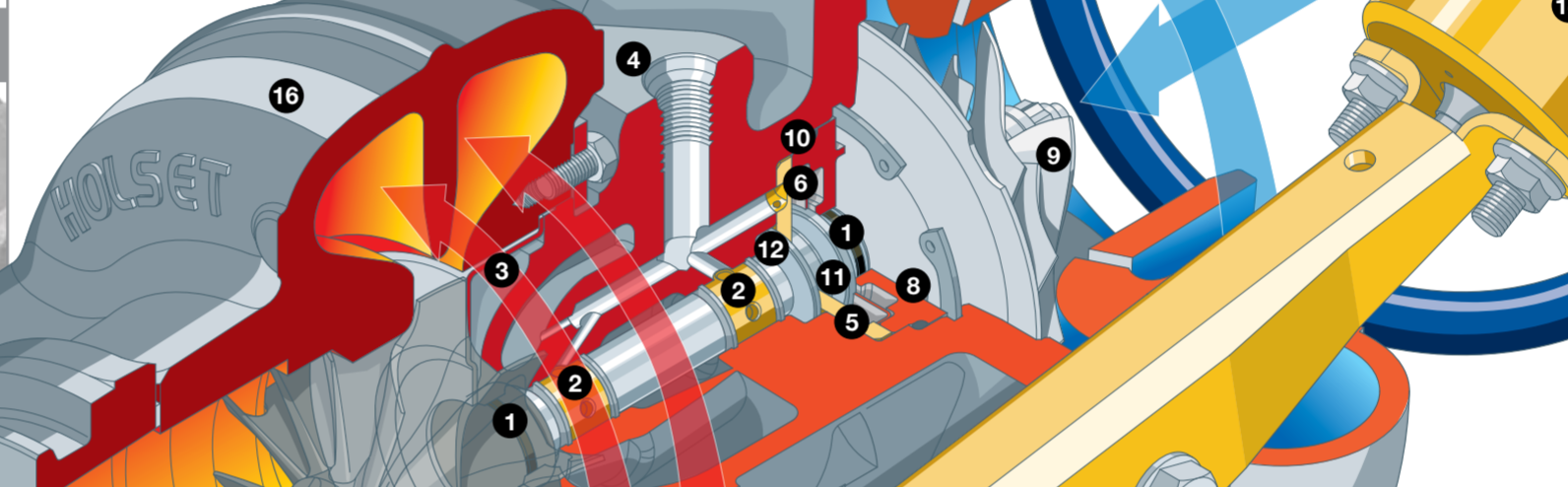
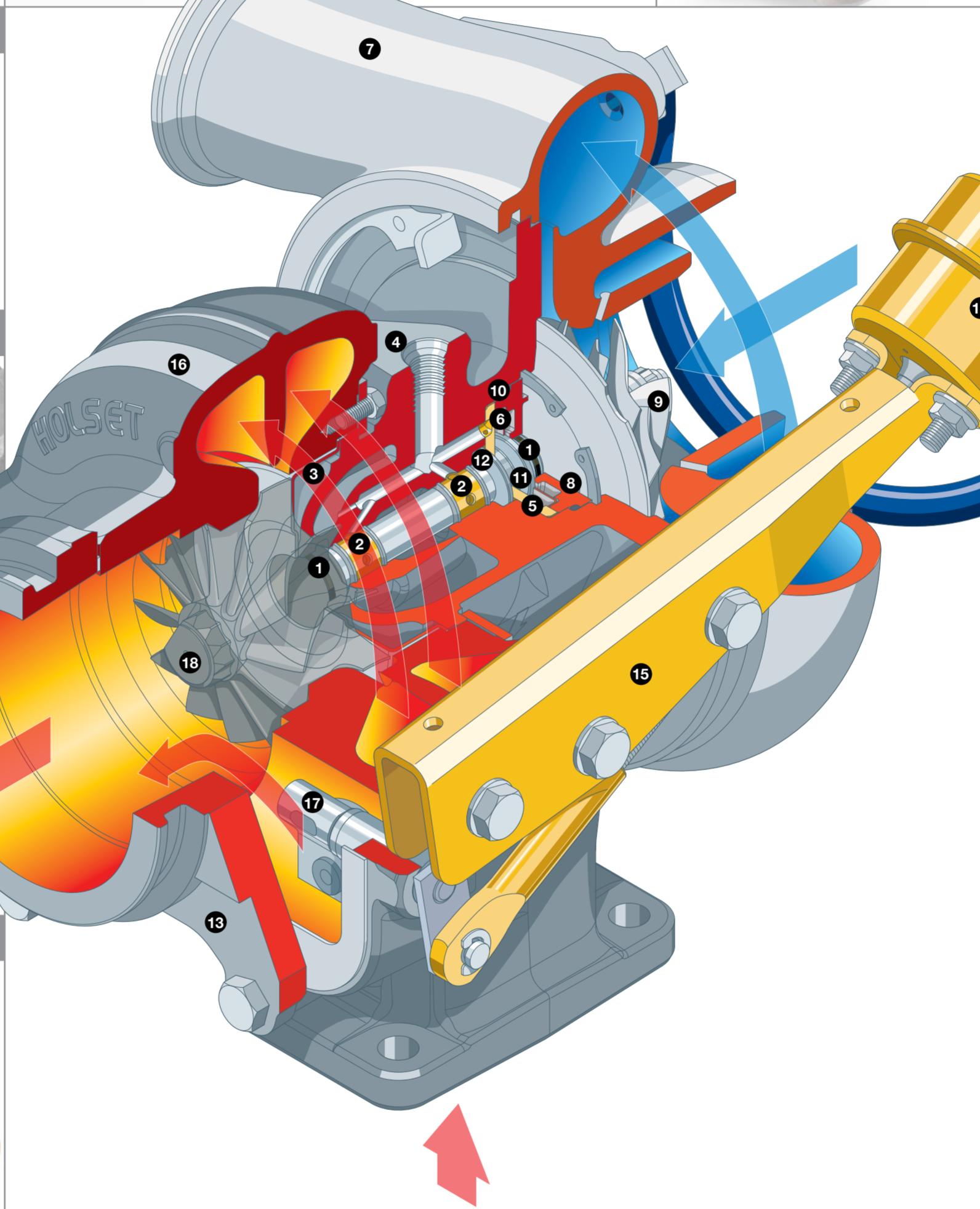
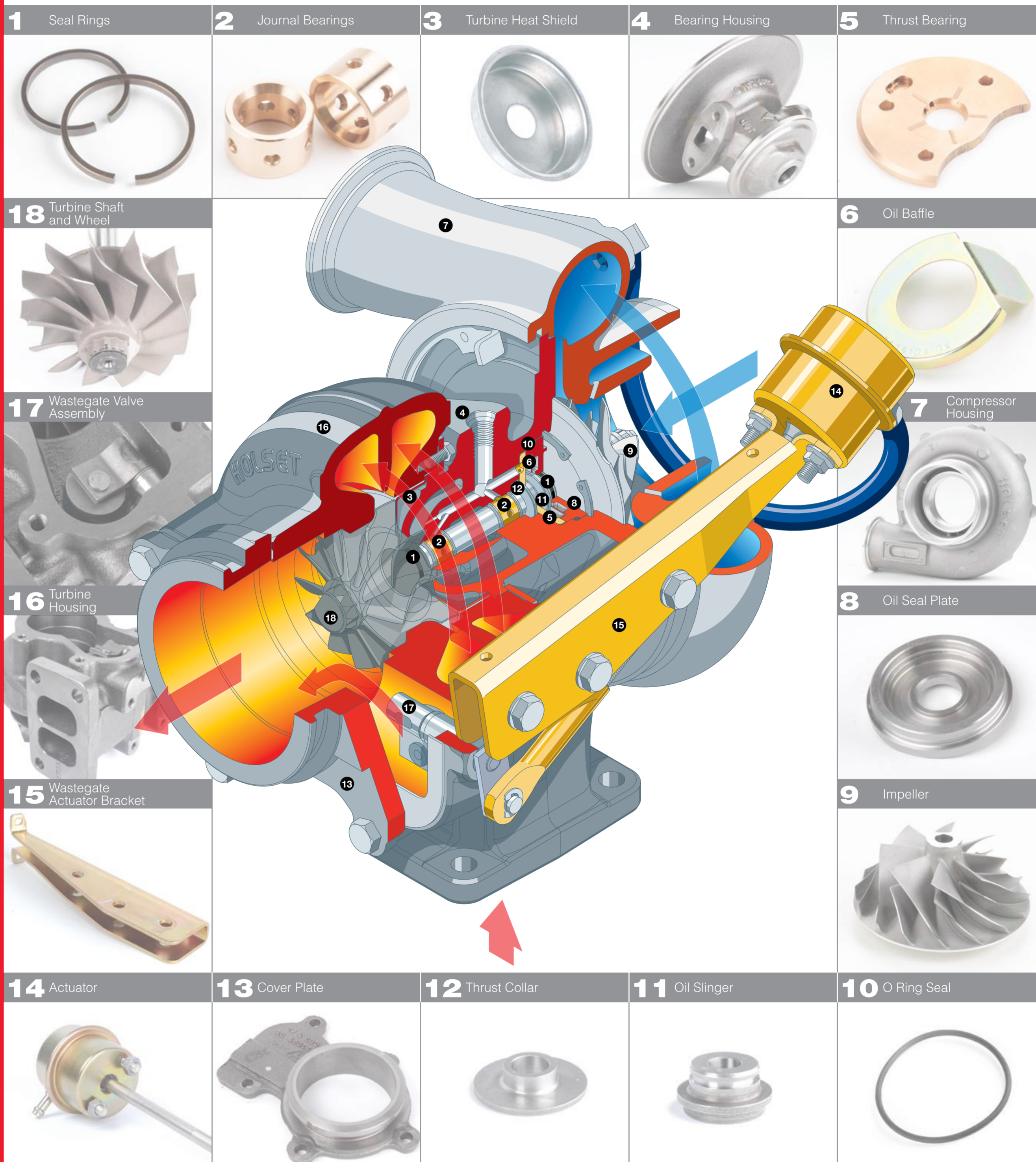

For more information visit:
www.holsetaftermarket.com

HOLSET[®]
TURBOCHARGERS

Turbocharger Troubleshooting Matrix

Loss of power, excess smoke, high fuel consumption, overheating, high exhaust temperatures and oil leakages from the turbocharger are all symptoms that could indicate turbocharger malfunction. However, these faults are often wrongly attributed to the turbocharger because defects in other components can produce the same symptoms. The turbocharger performance can only be impaired by mechanical damage or blockage caused by dirt.

This checklist provides a comprehensive list of the most common symptoms related to turbocharger failure. **BEFORE** replacing a turbocharger, verify the problem by consulting the chart below. If, after taking the appropriate action problems still persist, please contact your nearest authorised Holset distributor for advice.

	Engine running hot	Poor transient response	Smoke	Engine lacks power	Black exhaust smoke	Blue exhaust smoke	High oil consumption	Turbocharger noisy	Cyclic sound from the turbocharger	Oil leak from compressor seal	Oil leak from turbine seal
Dirty air cleaner Clean or replace element according to manufacturer's recommendations	●	●	●	●	●	●	●			●	
Restricted compressor intake duct Remove restriction or replace damaged parts as required	●	●	●		●	●	●	●	●	●	
Restricted air duct from compressor to intake manifold Replace seals, gaskets or tighten fasteners as required	●	●		●	●			●			
Restricted intake manifold Refer to engine manufacturer's manual and remove restriction	●	●		●	●			●			
Air leak in feed from air cleaner to compressor Replace seals, gaskets or tighten fasteners as required								●			
Air leak in feed from compressor to intake manifold Replace seals, gaskets or tighten fasteners as required	●	●	●	●	●	●	●	●			
Air leak between intake manifold and engine Refer to engine manufacturer's manual and replace gaskets or tighten fasteners as required	●		●	●	●	●	●	●			
Foreign object in exhaust manifold (from engine) Refer to engine manufacturer's manual and remove obstruction				●	●	●	●	●		●	
Restricted exhaust system Remove restriction or replace damaged parts as required	●			●	●					●	
Exhaust manifold cracked, gaskets blown or missing Refer to engine manufacturer's manual and replace gaskets or damaged parts as required		●	●	●	●			●			
Gas leak at turbine inlet/exhaust manifold joint Replace gasket or tighten fasteners as required		●	●	●	●			●			
Gas leak in ducting after turbine outlet Refer to engine manufacturer's manual and repair leak		●						●			
Restricted turbocharger oil drain line Remove restriction or replace damaged parts as required						●	●			●	●
Restricted engine crankcase breather Refer to engine manufacturer's manual and clear restriction						●	●			●	●
Turbocharger bearing housing sludged or coked Change engine oil and oil filter, overhaul or replace turbocharger as required						●	●			●	●
Fuel injection pump or fuel injectors incorrectly set Refer to engine manufacturer's manual and replace or adjust faulty components as required		●	●	●	●						
Engine valve timing incorrect Refer to engine manufacturer's manual for correct settings and adjust as required				●	●						
Worn engine piston rings or liners Refer to engine manufacturer's manual and repair as required				●	●	●	●			●	●
Burnt valves and/or pistons Refer to engine manufacturer's manual and repair as required				●	●	●	●			●	●
Excessive dirt build-up on impeller and/or diffuser vanes Clean in accordance with the appropriate Holset repair manual				●	●	●	●	●	●	●	●
Turbocharger damaged Find and correct cause of failure, repair or replace turbocharger as necessary				●	●	●	●	●		●	●
Failed diaphragm Replace using correct Actuator Service Kit	●							●			
Siezed valve Free valve/replace complete turbine housing sub-assembly	●	●									
Leaking hose Replace hose and clips	●							●			
Wastegate mechanism set incorrectly Contact nearest authorised Holset distributor for correct setting details	●	●	●	●				●			

For more information visit:

www.holsetaftermarket.com

HOLSET[®]
TURBOCHARGERS